

REV.	ECN.NO.	MODIFY.CONTENT	DATE
A		NEW	2014/03/29

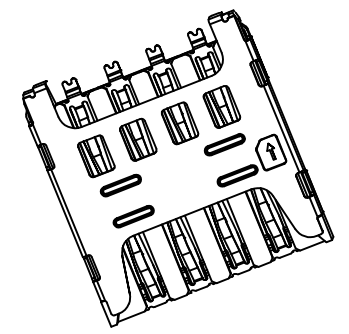

- NOTES:
- MATERIAL:SEE TABLE
    - Rated current:1.0A
    - Rated voltage:30V
    - Contact Resistance:50mΩ MAX
    - Insulation Resistance:1000MΩ MIN 500V DC
    - Dielectric withstanding voltage: 500V DC.
    - Solder ability:250℃±5℃, 10s±0.5s.
    - Durability:3000 Cycles Min.Contact Resistance50mΩMax
    - Mating and Unmating force  
Insertion Force 10N Max  
Withdrawal Fore 10N Max
    - Noraml Force:30~100g(Noraml card)  
Noraml working stroke: 0.3mm Min(Noraml card)
    - Operating condition:Temperature-40℃~+85℃;  
Humidity 80% R.H MAX
  - PLEASE CONTACT JITS SALES REPRESENTATIVE TO VERIFY PRODUCT DETAILS & AVAILABILITY

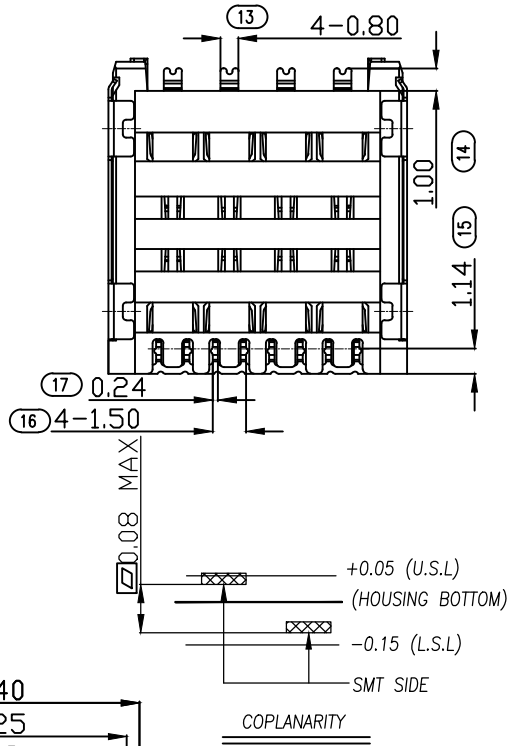
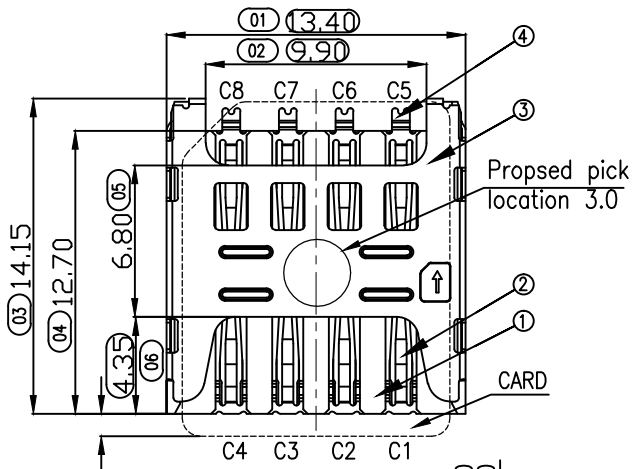
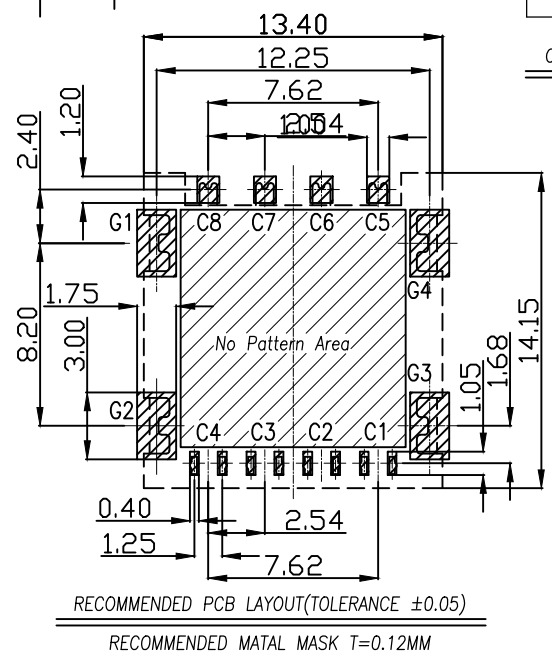
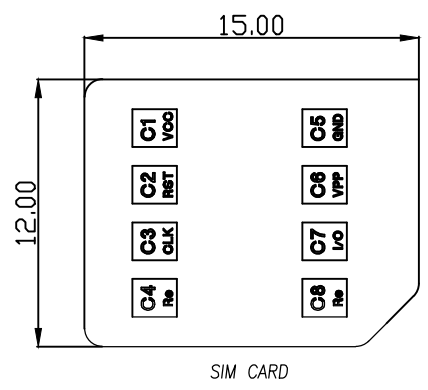
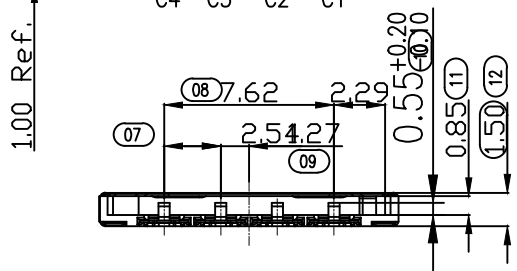

PIN No.	DESCRIPTION
C1	VCC (SUPPLY VOLTAGE)
C2	RST (RESET SIGNAL)
C3	CLK (CLOCK SIGNAL)
C4	RESERVED
C5	GND
C6	VPP (VARIABLE SUPPLY VLOTAGE)
C7	I/O (DATA INPUT/OUTPUT)
C8	RESERVED
G1~G4	GND

4	TERMINAL 2	4PCS	C5210R	CONTACT:1u"Au;solder:1u"Au;60u"NI PLATING
3	COVER	1PCS	SUS304	solder:1u"Au;30u"NI PLATING
2	TERMINAL 1	4PCS	C5210R	CONTACT:1u"Au;solder:1u"Au;60u"NI PLATING
1	HOUSING	1PCS	LCP	BLACK
NO.	PART NAME	QUANTITY	MATEIAL	COLOR/PLATING

GENERAL TOLERANCE		DWG NO.	JYSA1107-001	APPD:	WIND	Scale	1:1
X.±0.45	x.'±5'	Title	8PIN MICRO SIM CARD H1.50 (防潰PIN)	CHKD:		UNIT	mm
.X±0.35	.x'±2'			DR:			
.XX±0.25	.xx'±1'	Part NO.	JYS-SIM150-107	Date	2014/03/29		
.XXX±0.15	.xxx'±0.5'						
SHEET	1/1			Shenzhen <b>JYSCONN Electronics Co., LTD.</b>			

REV.	ECN.NO.	MODIFY.CONTENT	DATE
A		NEW	2014/03/29

User Direction of Unreeling →

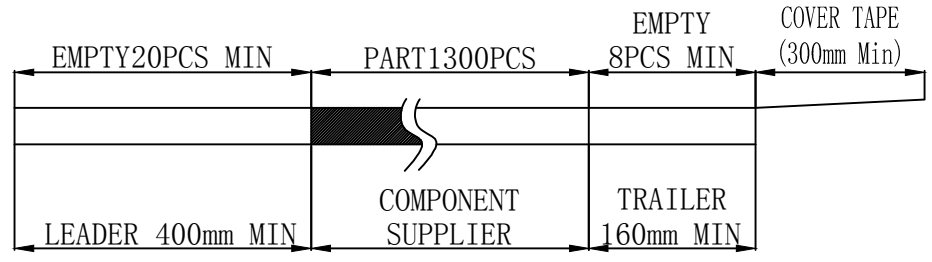
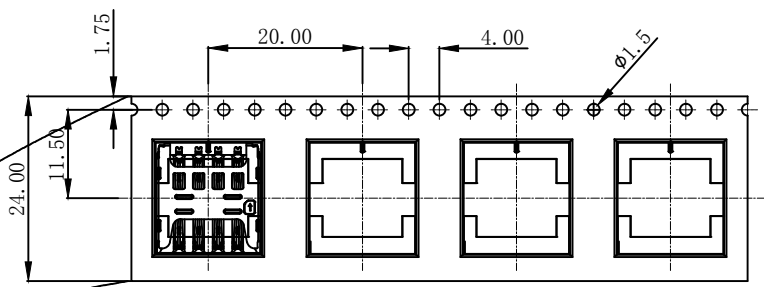

COVER TAPE PEELING ANGLE: 165°~180°  
PEELING FORCE: 20~130g

CARRIER TAPE

User Direction of Unreeling →

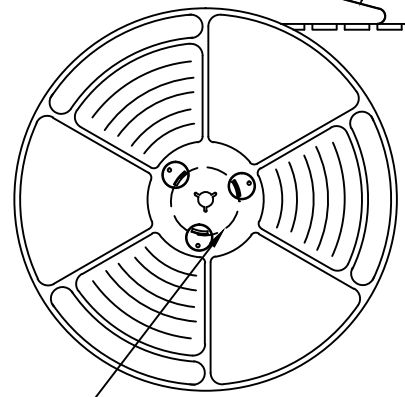

DETAIL B

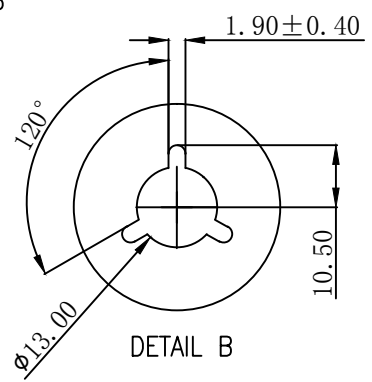

NOTES

1. NUMBER OF CONNECTORS: 1300PCS/REEL
2. LEAD TAPE LENGTH
3. QUANTITY: 10400PCS/CARTON
4. WEIGHT :  
3.1 NET WEIGHT : 3.33Kg  
3.2 GROSS WEIGHT : 6.55Kg

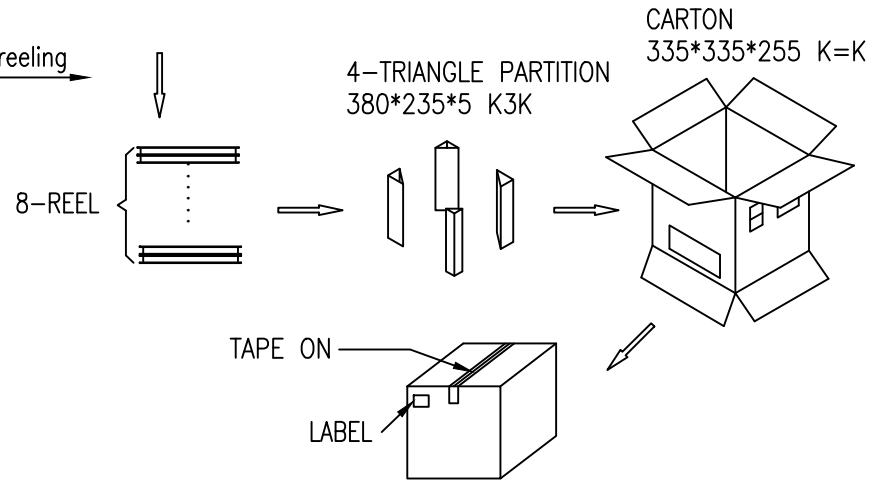

GENERAL TOLERANCE		DWG NO.	JYSA1107-001	APPD:	WIND	Scale	1:1
X.±0.45	x.'±5'	Title	8PIN MICRO SIM CARD H1.50 (防渍PIN) 包装图	CHKD:		UNIT	mm
.X±0.35	.x'±2'			DR:			
.XX±0.25	.xx'±1'	Part NO.	JYS-SIM150-107	Date	2014/03/29		
.XXX±0.15	.xxx'±0.5'			Shenzhen <b>JYSCONN Electronics Co., LTD.</b>			
SHEET	1/1						