

REV.	ECN.NO.	MODIFY.CONTENT	DATE
A0		NEW	2018/05/17

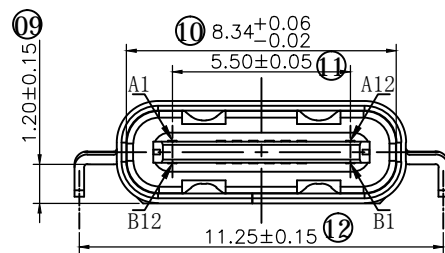
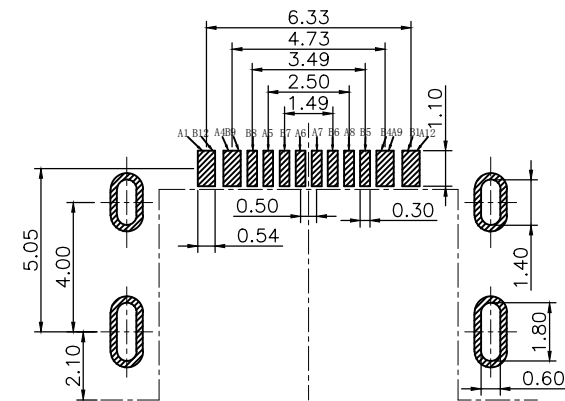
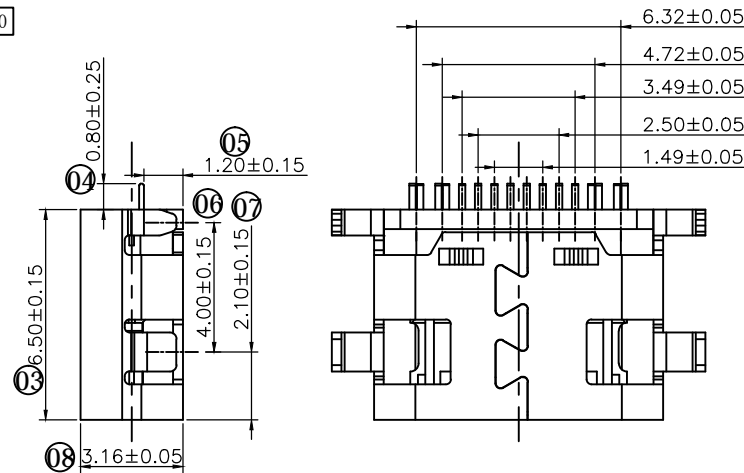
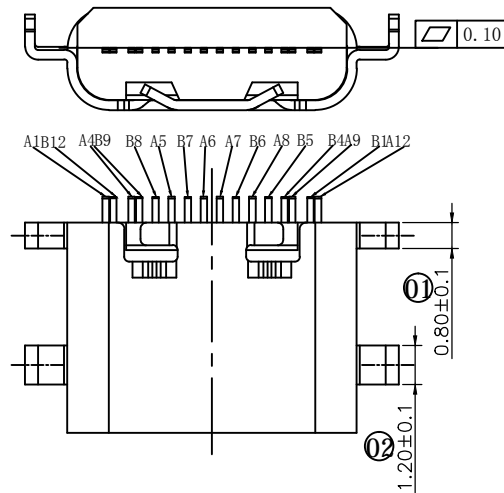

NOTES:

1. MECHANICAL: MATING FORCE: 5-20N .
UNMATING FORCE: 8-20N .
DURABILITY: 10000 CYCLES MIN.

2. ELECTRICAL:
CURRENT: 5.0A MAX
VOLTAGE: 20V MAX
WITHSTANDING VOLTAGE: 100V AC
CONTACT RESISTANCE: 40 mΩ MAX INITIAL;
50 mΩ MAX AFTER 10000 CYCLES

3. ENVIRONMENTAL :
OPERATING TEMPERATURE RANGE -30° C ~ +80° C
4. Salt Spray: 24H

A1	GND	B12	GND
A2		B11	
A3		B10	
A4	VBUS	B9	VBUS
A5	CC1	B8	SBU2
A6	D+	B7	D-
A7	D-	B6	D+
A8	SBU1	B5	CC2
A9	VBUS	B4	VBUS
A10		B3	
A11		B2	
A12	GND	B1	GND

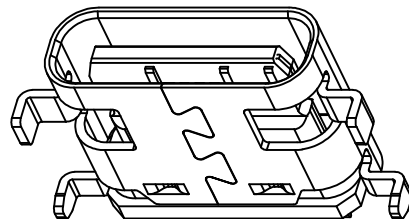

BOM			
序号	名称	用量	品名规格
1	外壳	1	Typec 16PIN 沉板 1.2 外壳 SUS304 T=0.30mm
2	Molding 3	1	Typec 16PIN 沉板 1.2 Molding C7025 T=0.15 PA9T黑色 半成品
2.1	Molding 1	1	Typec 16PIN 沉板 1.2 Molding A C7025 PA9T黑色
2.2	Molding 2	1	Typec 16PIN 沉板 1.2 Molding B C7025 PA9T黑色
2.3	卡勾	1	Typec 16PIN 沉板 卡勾 SUS301 T=0.15mm

GENERAL TOLERANCE		DWG NO.	JYSA180517	APPD:	WIND	Scale	1:1
X.±0.45	x.'±5'	Title	USB CF 16PIN (L=6.5) MID MOUNT 1.20	CHKD:		UNIT	mm
.X±0.35	.x'±2'			DR:			
.XX±0.25	.xx'±1'	Part NO.	JYS-USB120-087	Date	2018/05/17		
.XXX±0.15	.xxx'±0.5'						
SHEET	1/2	JYSCONN Electronics Co., LTD.					

REV.	ECN.NO.	MODIFY.CONTENT	DATE
A0		NEW	2018/05/17

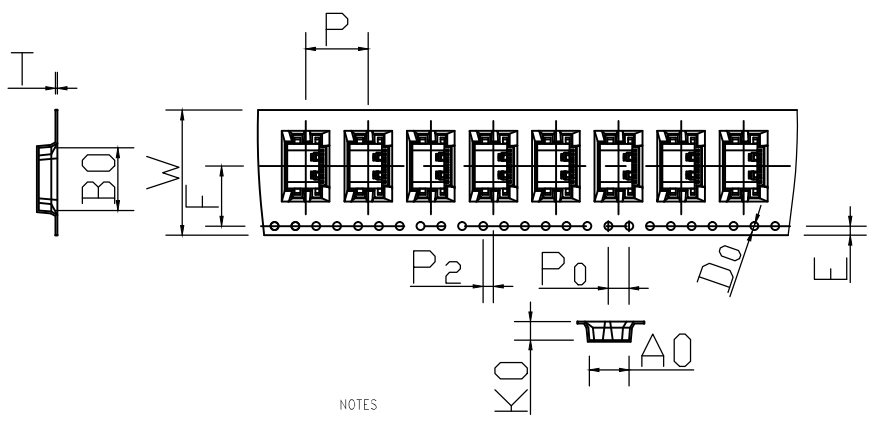
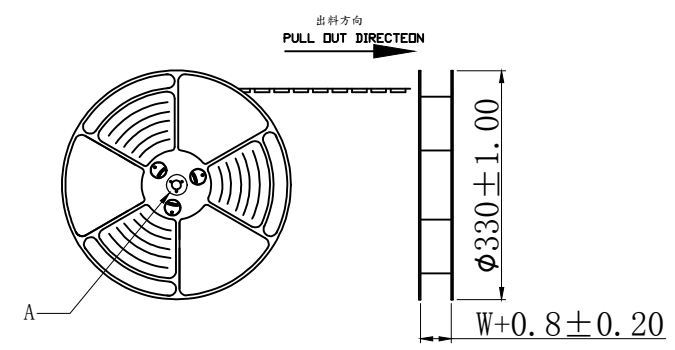

NOTES

1. 帶子引導長度
LEAD TAPE LENGTH
出料方向
PULL OUT DIRECTION

2. 上帶 剝力力為: 0.1~1.3N(10.2gf~130gf)
PEELING OFF FORCE OF TOP TAPE: 0.1~1.3N(10.2gf~130gf)
出貨運輸過程中一定注意:
THIS REQUIREMENT SHOULD BE APPLIED AT SHIPMENT:
卷帶在運輸過程中不能散開
PEELING OFF SHOULD NOT BE ALLOWED DURING TRANSPORTATION

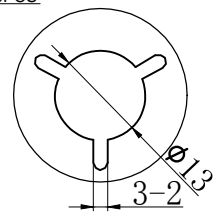
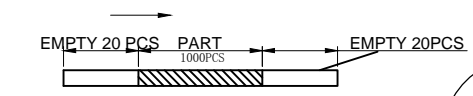

DETAIL: A
10:1

at small positioning hole of the carrier tape side).
標籤黏貼處 (朝捲裝包材的小定位孔一側)
Location of label sticking (label)

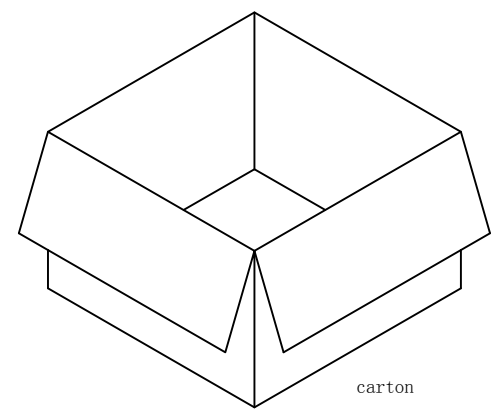
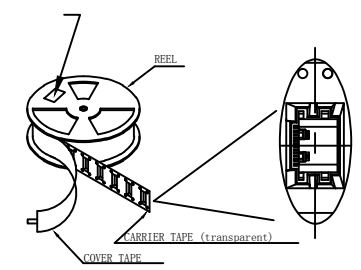
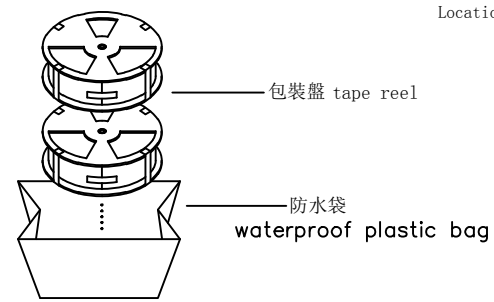

紙箱: 340mmX340mmX325mm

NOTE:

- 每捲包裝數量及每箱裝箱數量如左下表格。
Packing q'ty of each reel & carton as below table shown.
- 將裝滿產品的卷盤放入紙箱並以膠帶封口
Put reels in the carton and use adhesive tape to seal up.

W	24.00±0.3
A0	7.6±0.1
B0	12.0±0.1
K0	3.55±0.1
P	12.00±0.1
F	11.50±0.1
E	1.75±0.1
D0	1.50±0.1
P0	4.00±0.1
P2	2.00±0.1
T	0.35±0.1

卷帶	規格: $\phi 330\text{mm}$	包裝數量: 10000PCS
紙箱	規格: 340mmX340mmX325mm	包裝數量: 10盤 (10000PCS)

GENERAL TOLERANCE		DWG NO.	JYSA180517	APPD:	WIND	Scale	1:1
X.±0.45	x.±5'	Title	USB CF 16PIN (L=6.5) MID MOUNT 1.20 包裝圖	CHKD:		UNIT	mm
.X±0.35	.x'±2'			DR:			
.XX±0.25	.xx'±1'	Part NO.	JYS-USB120-087	Date	2018/05/17		
.XXX±0.15	.xxx'±0.5'						
SHEET	2/2						
JYSCONN Shenzhen JYSCONN Electronics Co., LTD.							